

**Model 102 SB**  
**Model 212 SB**  
**Model 422 SB**

High Performance Powered Subwoofers

422 SB

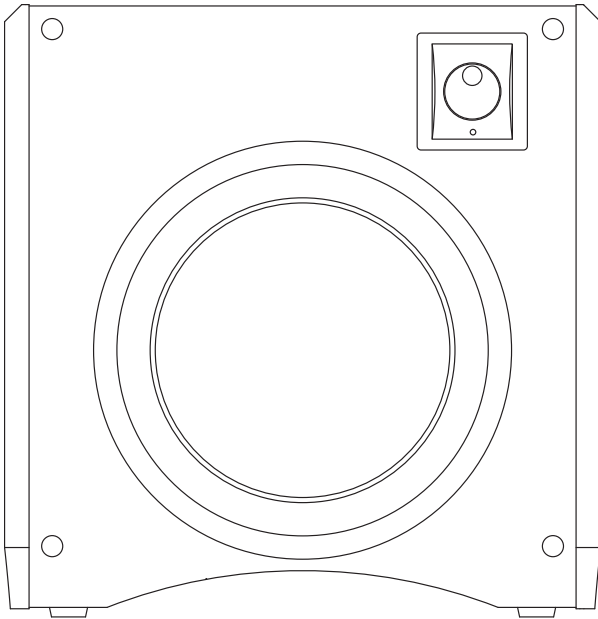

212 SB

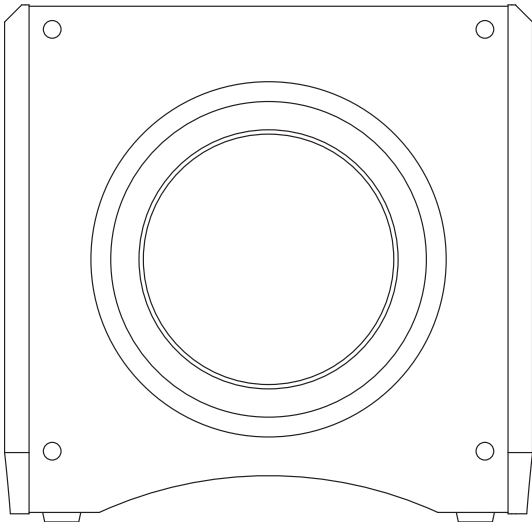

102 SB

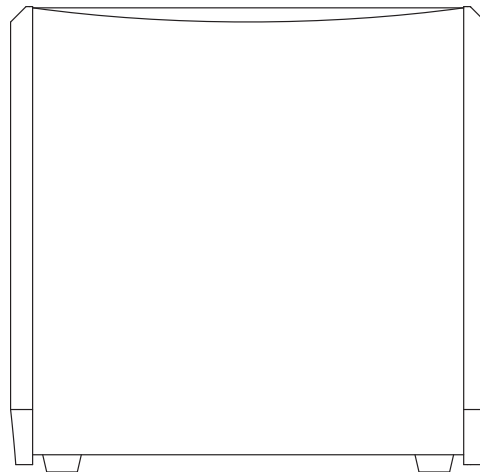

 **Atlantic Technology**<sup>®</sup>  
*bringing entertainment home*<sup>™</sup>

Instruction Manual

## Safety Precautions



**CAUTION:** To reduce the risk of electric shock, do not remove the cover (or back). No user serviceable parts inside. Refer to qualified personnel.

**WARNING:** To reduce the risk of fire or electric shock, do not expose this appliance to rain or moisture. This device generates a fair amount of heat. Make sure nothing blocks the ventilation openings on the top and bottom of the unit.



The lightning flash with arrowhead, within an equilateral triangle, is intended to alert the user to the presence of uninsulated “dangerous voltage” within the product’s enclosure that may be of sufficient magnitude to constitute a risk of electrical shock to persons.



The exclamation point within an equilateral triangle is intended to alert the user to the presence of important operating maintenance (servicing) instructions in the literature accompanying the appliance.

## For Future Reference

Record your serial numbers and date of purchase here:

Model Number \_\_\_\_\_

Serial Number \_\_\_\_\_

Date of Purchase \_\_\_\_\_

The serial number is found on the back panel.

## Table of Contents

<b>2</b>	<b>Model 102, 212 and 422 SB</b>
<b>3</b>	<b>102 and 212 SB Subwoofer Rear Panel</b>
<b>4</b>	<b>422 SB Subwoofer Rear Panel</b>
<b>5</b>	<b>Features</b>
<b>6</b>	<b>Connecting Your Subwoofer</b>
6	Subwoofer Line Out to Low Level In
6	Using the Low Level Output
6	Power Connection
<b>7</b>	<b>Low Level Connections with One Subout/LFE Output</b>
<b>8</b>	<b>Low Level Connections with Two Subout/LFE Outputs</b>
<b>9</b>	<b>Placement and Operation</b>
<b>9</b>	<b>System Setup</b>
9	Subwoofer Tuning Without an SPL Meter or Test Tones
9	How Much is Enough?
10	Dual Subwoofer Placement
10	Using the Subwoofer Crossover Control
10	The Phase Invert Control
10	A Word About Bass, Center Channel Modes and System Set Up
<b>10</b>	<b>Care of Your Subwoofer</b>
<b>11</b>	<b>Subwoofer Troubleshooting Guide</b>
<b>11</b>	<b>Specifications</b>

# Model 102, 212 and 422 SB High Performance Powered Subwoofers

Congratulations on your purchase of an Atlantic Technology powered subwoofer. A well designed subwoofer, properly integrated into your system, will enhance your listening pleasure dramatically by providing the bass foundation upon which most music and special effects are built.

These subwoofers are capable of delivering very high output levels and wide dynamic range. When properly placed, these subs will provide smooth in-room bass response down to approximately 25Hz, with a peak SPL of over 102dB in a normal sized room.

Their high-current amplifiers, coupled with their rugged long-throw woofers in sealed enclosures, generates accurate deep bass with a minimum of distortion.

Your Atlantic Technology powered subwoofer will smoothly integrate with virtually all brands of loudspeakers on the market. From the rock-solid amplifier to the easily accessible controls, this is one of the most versatile high performance subwoofers you can buy.

Copyright © 2004 Atlantic Technology International.

Specifications are those in effect at the time of printing. Atlantic Technology reserves the right to change specifications or designs at any time without notice. THX and THX Ultra 2 are registered trademarks of Lucasfilm, Ltd. Dolby Digital, AC-3, Dolby Stereo and Dolby Pro Logic are trademarks of Dolby Laboratories Licensing Corporation.

## 102 and 212 SB Subwoofer Rear Panel

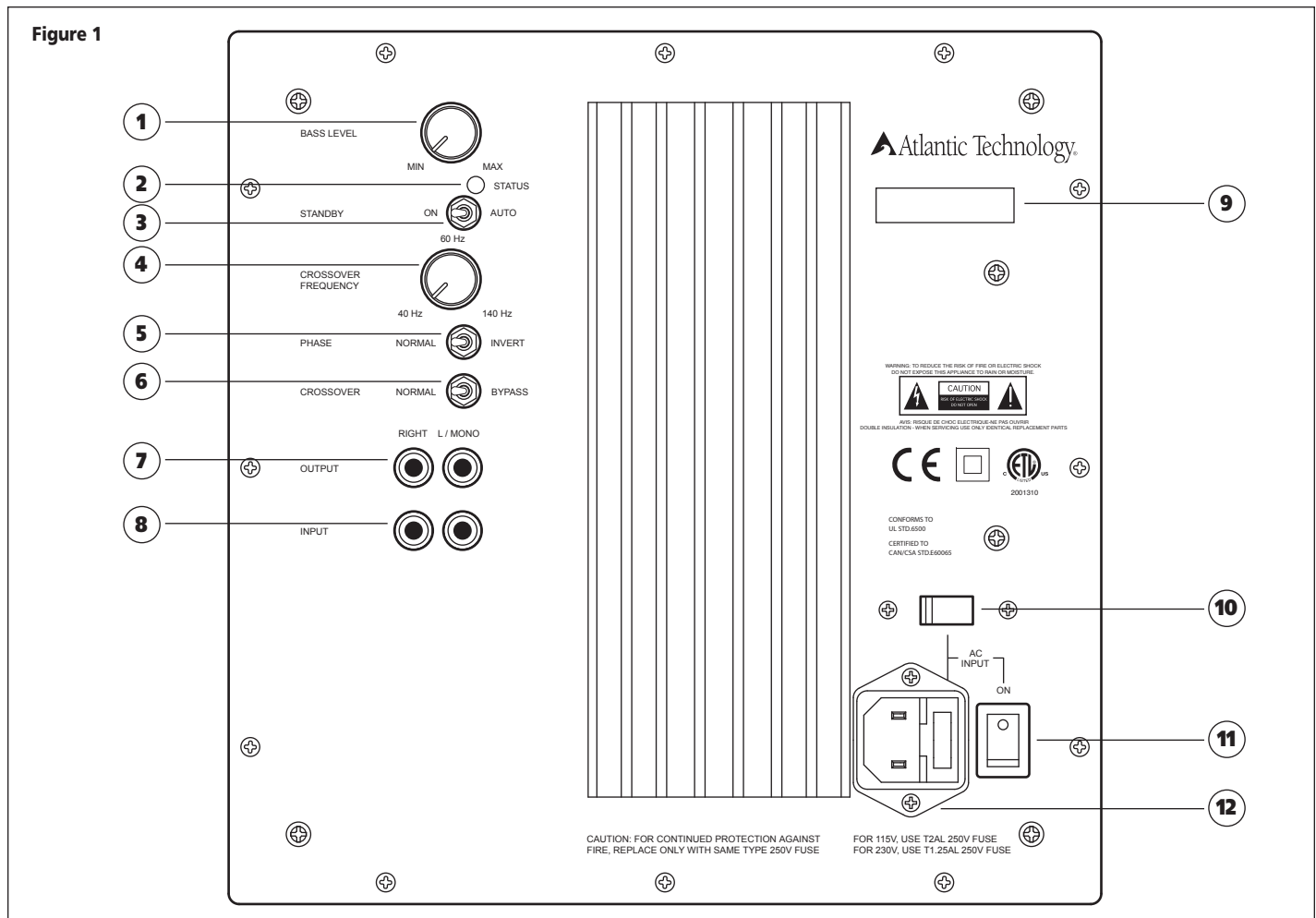

- 1 Variable Level Control**  
Use this control to set the level of bass desired
- 2 Status LED**  
This will be green for "on" condition, amber for "standby"
- 3 Standby Switch**  
When in ON position, the amplifier will always be on. When in the AUTO position, the amplifier will be in Automatic Standby Mode. (pages 5 and 9)
- 4 Crossover Control**  
An adjustable (40Hz to 140Hz) @ 18dB per octave low-pass crossover. (pages 5 and 9)
- 5 Phase Switch**  
This switch allows precise acoustic matching with satellite speaker systems whose output may be phase reversed. (pages 5 and 10)
- 6 Crossover Switch**  
When in the NORMAL position, adjustment of the crossover can be made by the Crossover Control. If being fed a pre-filtered or THX signal, place the switch at the BYPASS position. (pages 5 and 9)
- 7 Low Level Output**  
The outputs allow daisy chaining of multiple subwoofers, or as a return path back to the processor. (pages 5 and 6)
- 8 Low Level Input**  
Use the input to connect to the subwoofer or LFE line out from your processor/receiver. (pages 5 and 6)
- 9 Product Serial Number**  
Write this number in the space provided on page 2 for future reference.
- 10 Voltage Select Switch**  
Voltage switch for use in different countries. This switch will be set when you receive the unit. Change this setting only when you are sure your application requires it. For US, the switch should be set to the 110-120V position.
- 11 On/Off Switch**  
Use this switch to turn the amplifier completely on or off.
- 12 AC Input**  
Use the included power cord to connect your amplifier to a wall outlet. (pages 5 and 6)

## 422 SB Subwoofer Rear Panel

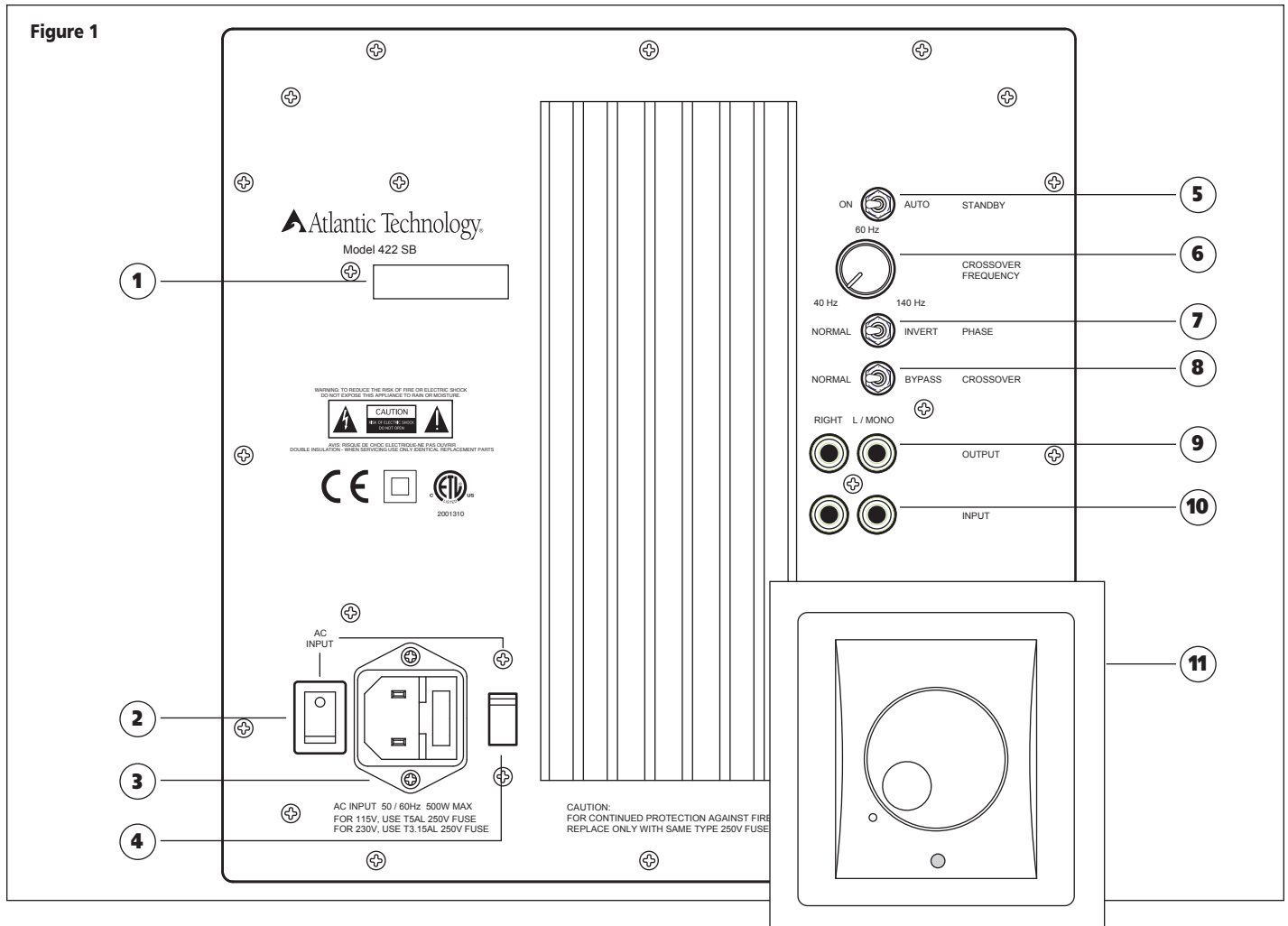

- 1 Product Serial Number**  
Write this number in the space provided on page 2 for future reference.
- 2 On/Off Switch**  
Use this switch to turn the amplifier completely on or off.
- 3 AC Input**  
Use the included power cord to connect your amplifier to a wall outlet. (pages 5 and 6)
- 4 Standby Switch**  
When in ON position, the amplifier will always be on. When in the AUTO position, the amplifier will be in Automatic Standby Mode. (pages 5 and 9)
- 5 Voltage Select Switch**  
Voltage switch for use in different countries. This switch will be set when you receive the unit. Change this setting only when you are sure your application requires it. For US, the switch should be set to the 110-120V position.
- 6 Crossover Control**  
An adjustable (40Hz to 140Hz) @ 18dB per octave low-pass crossover. (pages 5 and 9)
- 7 Phase Switch**  
This switch allows precise acoustic matching with satellite speaker systems whose output may be phase reversed. (pages 5 and 10)
- 8 Crossover Switch**  
When in the NORMAL position, adjustment of the crossover can be made by the LowPass Control. If being fed a pre-filtered or THX signal, place the switch at the BYPASS position. (pages 5 and 9)
- 9 Low Level Output**  
The outputs allow daisy chaining of multiple subwoofers, or as a return path back to the processor. (pages 5 and 6)
- 10 Low Level Input**  
Use the input to connect to the subwoofer or LFE line out from your processor/receiver. (pages 5 and 6)
- 11 Front Mounted Variable Level Control and Status LED**  
Shown in greater detail on page 9

## Features

Your Atlantic Technology powered subwoofer has been engineered using the latest technology and finest components available. It features:

- **A long-throw composite cone driver with a vented motor structure and 2" high temperature, 4-layer voice coil**

This powerful driver has a very stiff cone that acts like a piston throughout its operating range. Its massive magnetic motor assembly and high temperature component parts deliver exceptional performance and reliability.

- **Sealed enclosure design for low distortion and deep bass output**

Sealed enclosure woofer designs are inherently low in distortion, and deliver deep smooth bass response with a gradual and predictable roll-off below resonance. As with all Atlantic Technology subwoofers, we have paid close attention to providing accurate musical bass reproduction along with terrific special effects.

- **High-current amplifiers**

The output stage of these amplifiers are capable of very high current delivery for exceptional driver control and cool operation. They have been precision matched and equalized to our rugged drivers. Together they deliver powerful, controlled bass with great articulation and authority.

- **A useful in room working frequency range of 25Hz to 150Hz**

Many subwoofers offer specifications that look great on paper, but in real world use deliver less than promised. Atlantic Technology subwoofers are over-designed to ensure that they will deliver their rated performance in your room, when properly placed and adjusted.

- **An adjustable (40Hz to 140Hz) @ 18dB per octave LowPass crossover**

The steep upper end roll-off slope of 18dB per octave allows for much better bass integration with the satellite speakers while making the woofer less localizable.

**NOTE:** *If you are using a surround Processor/Receiver that includes its own filtered subwoofer output (or a THX Certified Processor/Receiver), we strongly recommend that you set the crossover control to the Bypass position.*

- **Two low level inputs, two low level outputs**

The outputs allow daisy chaining of multiple subwoofers, or as a return path back to the processor.

- **A Phase Invert switch (Normal/Invert)**

This switch allows precise acoustic matching with satellite speaker systems whose output may be phase reversed. This switch also allows you to compensate for unusual room acoustics that occur when the woofer is physically separated from the main speakers. Be sure to try the Phase switch in both positions when you set up your subwoofer. Even if you've simply changed the built-in crossover settings it's a good idea to try the Phase switch in both positions, since the crossover control and the Phase switch acoustically interact with each other. Pay particular attention to the transition of bass from the woofer to the satellites, listening for smooth and well defined bass throughout the range.

- **A convenient front panel mounted Level Control (422 SB)**

- **Automatic standby operation, LED indicator**

Automatic standby features signal sensing turn-on with 7-10 minute turn-off delay. There's a multi-color LED status indicator that lets you know when the unit is on or in standby. Automatic Standby can be defeated by placing the rear mounted switch in the ON position.

- **An AC cord power input socket**

Your subwoofer comes supplied with a heavy-duty detachable power cord.

- **Designed and built to meet all current UL/CSA and European safety requirements**

## Connecting Your Subwoofer

Use the low-level (RCA jack) subwoofer line out of your surround sound receiver/processor. Simply connect your subwoofer with a high quality shielded cable as shown in the diagram on page 7. Please consult your processor/receiver manual for further information.

**WARNING:** To prevent risk of electrical shock or damage to your equipment, always unplug all component AC cords before proceeding with speaker and component connections! The last step in wiring your system should be plugging in the AC cords!

### Subwoofer Line Out to Low Level In

Run an RCA cable from your receiver's Sub Out jack to the L/Mono input jack on the back of the subwoofer (Figure 3). If your receiver/processor has stereo subwoofer outputs, connect these to both the L/Mono and R jacks on the back of the subwoofer (Figure 4).

### Using the Low Level Output

If desired, you can run a low level signal through the subwoofer and out to another unit. This way you can add an additional subwoofer with minimal additional wiring. The signal that comes out of the output jacks is identical to the input signal.

### Power Connection

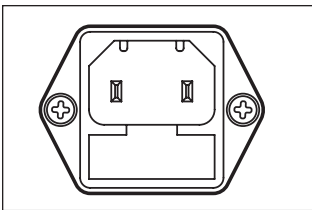

Connect the power cord to an AC outlet only after making all other connections to the subwoofer. This will avoid any chance of accidentally activating the subwoofer while wiring. Atlantic Technology does not recommend plugging the subwoofer

into the switched outlet of an amplifier, preamplifier, or receiver. The power demands of the subwoofer amplifier may exceed the power rating of the switched outlet and may damage the equipment.

**Figure 2**

AC Connection

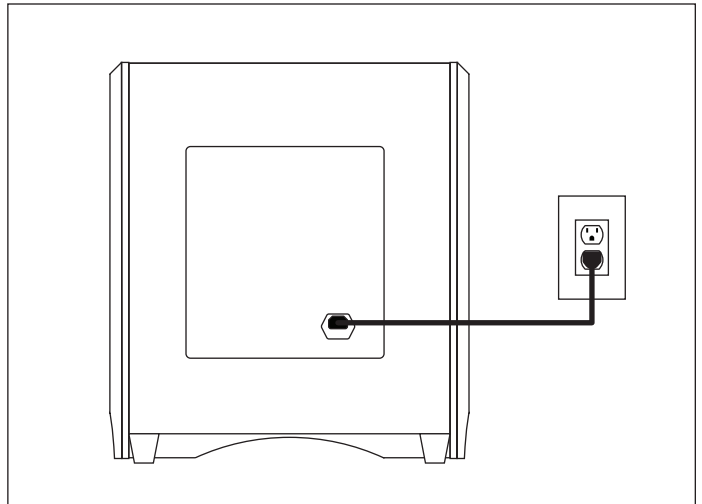

Your subwoofer is totally automatic in its operation. The automatic on/off circuitry will only activate the subwoofer in the presence of an audio signal from your system. After 7-10 minutes with no signal detected from the rest of the system, the amplifier will shut itself off and go back into standby mode. When the sub is in operating mode, the status LED will glow green. The LED will glow amber in the Standby mode and power consumption in this mode is negligible. Standby operation can be completely bypassed by placing the standby switch on the rear panel to the ON position.

## Low Level Connections with One Subout/LFE Output

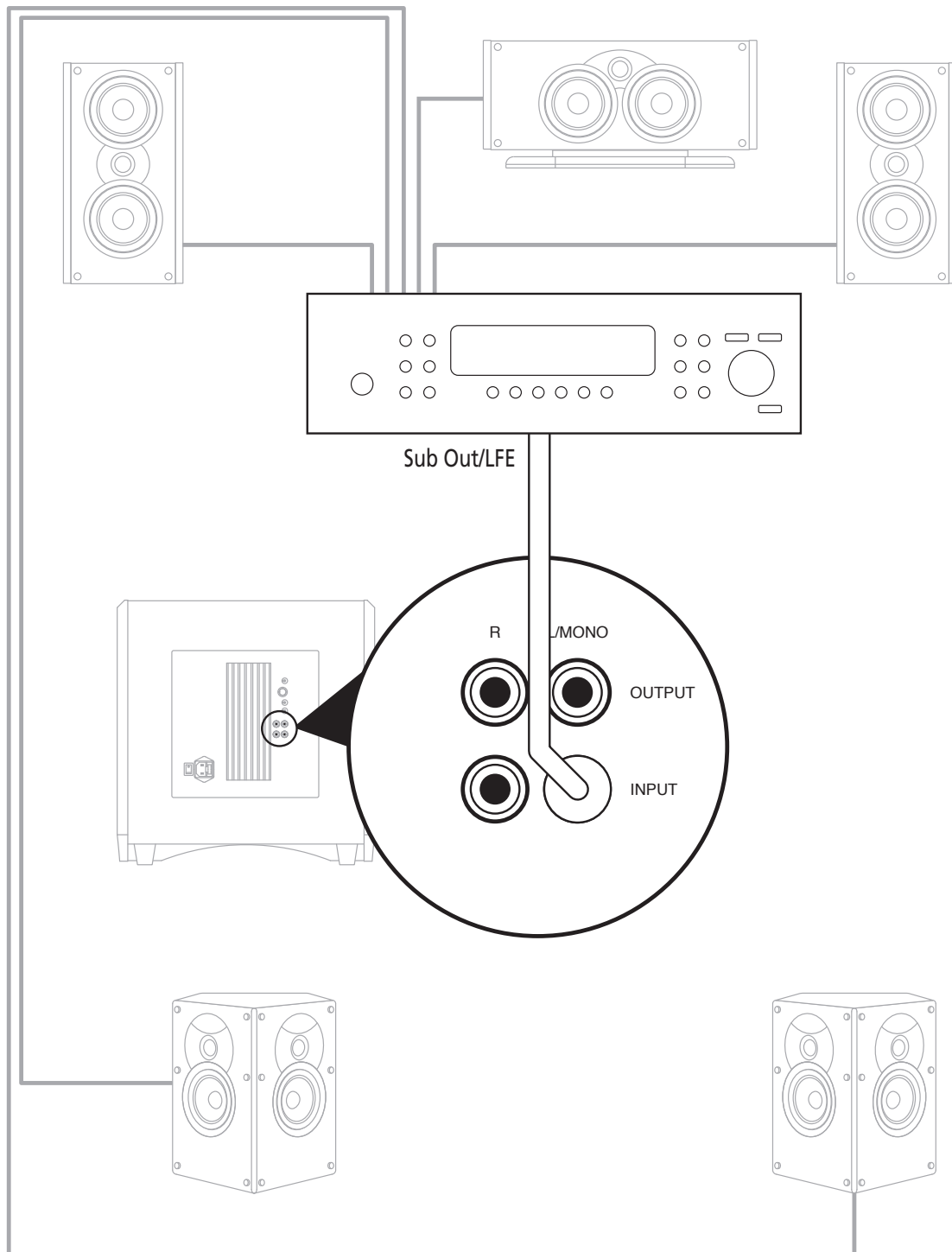
**Figure 3**

### Low Level Connections with Two Subout/LFE Outputs

Figure 4

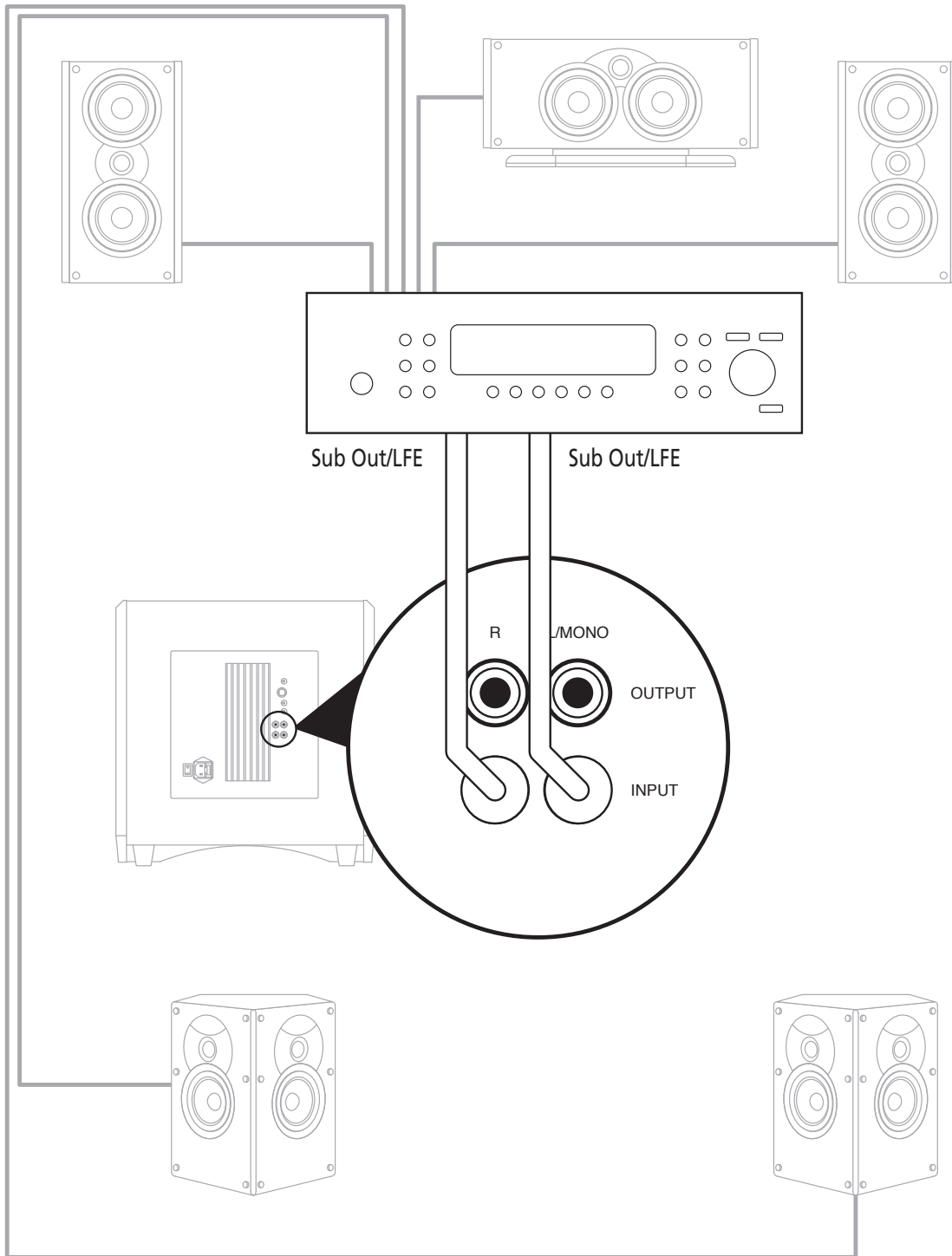



## Placement and Operation

Generally speaking, the best location for your new subwoofer is the front of the room, close to a corner (Figure 5). Every room has its own unique sound characteristics, and flexibility in the exact placement of the subwoofer is always desirable. The closer the subwoofer is placed to a wall and especially a corner, the more and deeper the bass response you will hear. Because of an acoustic phenomenon known as "room gain," a well-designed subwoofer playing in an acoustically-favorable room may well deliver low bass deeper than its rated response. However, in some rooms, corner placement can produce a "one note" boomy effect. Under such circumstances the subwoofer may work better away from the corner. Experiment to find the best position in your room.

**HELPFUL HINT:** A particularly useful experiment is to place the subwoofer right at the prime listening position (move your couch or chair out of the way and put the sub in its place). Then play something with good bass content (preferably music), and walk around the room, listening to the subwoofer's response. When you locate an area that has an ample amount of well defined bass, you've found a good potential place to locate the sub.

**Figure 5**

Typical arrangement for a single subwoofer in a home theater.

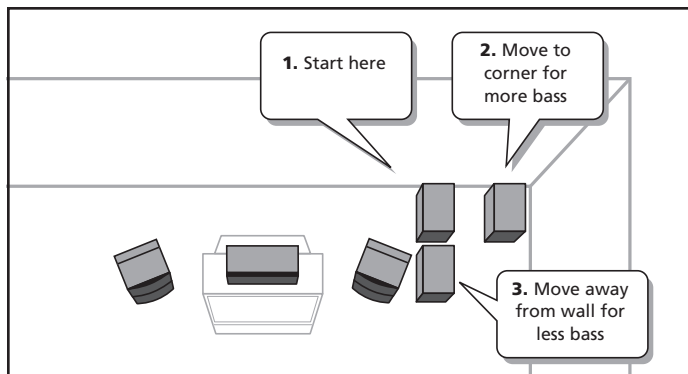

## System Set Up

When setting up a complete home theater we strongly recommend that you use a Sound Pressure Level meter. Radio Shack® has a good one that is very affordably priced (approximately \$40-50). To use this meter, turn on your system, put the Processor/Receiver in the Test Mode and set its main volume control to 0dB. Sit in the prime listening position, set the SPL meter to the 70dB scale, Slow Response, and C Weighting. Now, holding the meter pointed up and in front of you, let the system cycle its test tone from speaker to speaker and set every speaker to 75dB using the individual level settings in the Processor/Receiver. As tempting as it may be to set the subwoofer and/or surround speakers higher than 75dB, listen again after calibration and see if you can acclimate to these levels. Try watching several different movies and keep in mind that the goal is to have a system that sounds like you're actually "in the movie." When using the latest discrete digital electronics which include internal level controls for all channels, we recommend setting the 422 SB's front mounted Level Control to its Preset position and using the Processor/Receiver's built-in subwoofer level control.

On the 212 SB you can use the level control on the rear panel to make this adjustment. If you decide not to use an SPL meter try to set all the speaker levels the same using the Test Tones. Of course, this will be much more difficult without the meter, especially for the subwoofer.

**Figure 6**

(422 SB only) Front Panel Variable Level Control located behind the removable grille

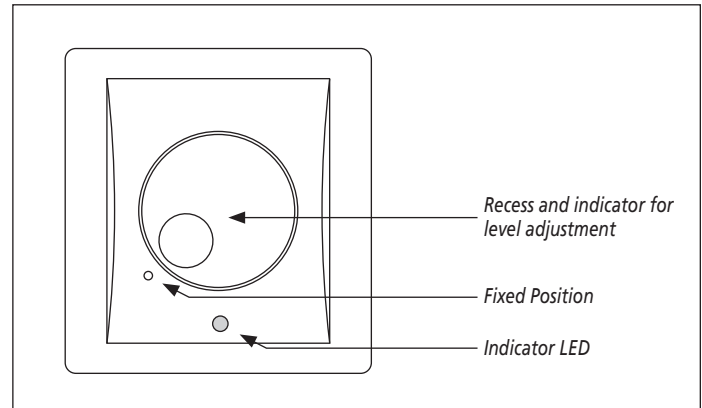

## Subwoofer Tuning Without an SPL Meter or Test Tones

Start your listening with the subwoofer Crossover control set at around 100Hz or in the Bypass position if you're using a THX Certified processor or unit with a built-in crossover. Set the phase switch to normal, and the front panel variable level control (Figure 6) to the Preset position. Play some music that you know has good bass content, and turn the level control up until you just start to hear the subwoofer working. Now, from your normal listening position, determine whether the subwoofer is playing loudly enough and filling in the bass frequencies of the music evenly. If adjustment is necessary, start by changing the setting in the processor or with the level control if your processor lacks a subwoofer level adjustment.

If the bass seems too ponderous, boomy, or heavy, no matter how you set the level, try moving the subwoofer away from the wall/corner. If the bass seems too thin, try moving the subwoofer closer to the wall/corner. Small differences in positioning can make big differences in bass response. When you find a position that seems to work well, try switching the phase switch between its two settings, listening particularly to the transition from the subwoofer to the satellites.

## How Much is Enough?

Sometimes people prefer more bass impact for movies. Using the movie setting for music can result in overpowering and unnatural bass reproduction. You may wish to determine both a video level and an audio level if you find yourself falling into this camp. Remember however, the most common error people make when setting up their system is to play the subwoofer (and surrounds) too loudly. Of course, the Home Theater Police will not arrest you for this act. But should you desire the most accurate overall reproduction, a well balanced sound from bass to high-treble is the best way to get it. Have fun. Experiment. Enjoy.

## Dual Subwoofer Placement

When two subwoofers are used, you may wish to place them asymmetrically; that is, in slightly different positions in the room (Figure 7). This will reduce common mode room resonances that occur with symmetrically positioned subwoofers. You can also try placing the subwoofers in the same corner, if you wish. Experiments have shown this to be a viable means of producing smooth bass response in many rooms.

**Figure 7**

*Asymmetrical arrangement for 2 subwoofers in a home theater, for example, one closer to a corner than the other*

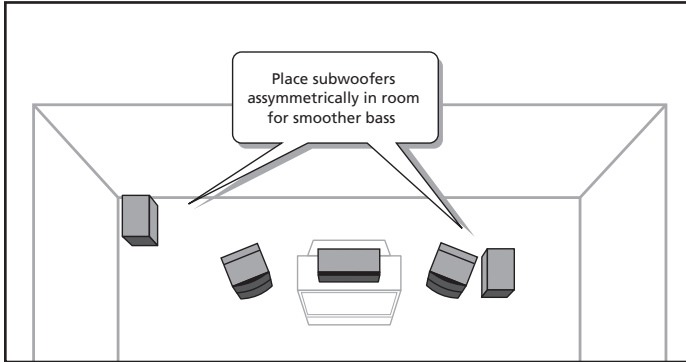

## Using the Subwoofer Crossover Control

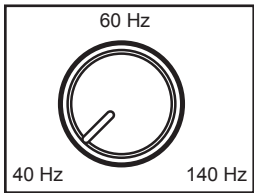

When used with the System 1200 or 2200, the Crossover control should be set at around 100Hz unless you are using a processor with its own built-in crossover. The goal is to optimize the performance of the system by ensuring that the subwoofer and satellites produce a cohesive and well integrated sound “picture.”

Many surround sound receivers and processors offer a choice of crossovers, typically between 80 Hz and 120 Hz. If yours does, we recommend using the 100Hz setting when using small speakers such as those in the System 1200 or 2200. Consult your electronics owner's manual for more details.

Higher crossover frequencies pass more bass but can sound boomy and may be more easily localized to the subwoofer. Higher crossover frequencies may be suitable, however, when using very small satellites that have no real low frequency performance. Settings lower than 80Hz should be employed if you are using larger speakers that have extended bass response. This way, the subwoofer will only reproduce the very lowest bass frequencies that are in the range where the large main speakers begin to roll off.

It's generally undesirable to have the main speakers and the subwoofer overlap too much. Larger speakers means a lower Low-pass crossover frequency, smaller speakers means a higher Low-pass crossover frequency. Consult the manufacturer's specified low frequency response for your main speakers to determine the appropriate Low-pass setting on your subwoofer. In the end, however, a little time spent experimenting will generally result in dramatically better bass response.

## The Phase Invert Control



A subwoofer operating out of phase with the rest of the system won't provide optimum low frequency performance. Also, the correct subwoofer

phase can enhance room acoustics. Since there is so much variation in the industry regarding phase, a switch that will reverse the phase of the subwoofer is provided on the amplifier panel. Listen to a monaural musical source with strong bass content. (For example, you can use the mono switch on an FM tuner or preamp, or use a Y-connector on the outputs of one of your source components to get a mono signal.)

Experiment with the position of the phase switch to get the smoothest bass. It should be obvious which is the correct setting. In particular, there will be a more integrated transition between the satellites and the subwoofer when they are properly phased.

## A Word About Bass, Center Channel Modes and System Set Up

Many surround processors and receivers feature a “Wide” and “Normal” mode for the center channel speaker. Atlantic Technology recommends that the center channel be operated in the “Normal” mode when using a powered subwoofer. The center channel speaker will sound more dynamic and the intelligibility of the system will generally be improved when in the “Normal” mode.

With discrete digital 5.1, 6.1, or 7.1 channel systems (Dolby Digital, DTS, etc.) many controllers provide a Bass Management option, which lets you set the front and rear speakers in a limited bandwidth (Small) or full range (Large) mode. When using a subwoofer with Atlantic Technology speakers we recommend setting such a controller to the Small position for all the speakers in the system.

## Care of Your Subwoofer

The 102 SB, 212 SB and 422 SB are constructed from Medium Density Fiberboard. MDF is a non-resonant material ideal for speaker system enclosures. To clean the cabinet you may use a soft cloth either dry or slightly dampened with clean water. Be careful not to wet the cabinet or allow any water to enter the cabinet seams. Avoid placing your speakers in direct sunlight or near a source of heat that may, over time, damage the finish.

**IMPORTANT:** *Save Your Boxes! If you can do so, save the carton, packing pieces and plastic bags that came with your subwoofer. They will be useful in case you move or have to ship your subwoofer for any reason. In any case, save all packing materials until you are certain that the system has suffered no damage in shipment. If you find such damage, either visible or internal, contact your dealer immediately for the proper return procedure.*

## Subwoofer Troubleshooting Guide

Once your subwoofer is set up, you should have many years of maintenance free enjoyment from your system. However, if you should encounter a problem, refer to the following guide to help you find the solution. If a problem persists, you should contact your local authorized Atlantic Technology dealer.

Problem	Possible Cause	Possible Solution
No bass output	AC power cord unplugged or plugged into a non-working outlet.	Plug into a working outlet.
	Input cables not securely connected or defective.	Check all connections, then try another input cable.
Audible buzz or hum	Input cable not securely connected or defective.	Check all connections, then try another input cable.
	Ground loop through antenna or cable TV system input.	Test by disconnecting antenna and/or cable system input leads. If hum goes away, install isolation balun(s) at that point.

## Specifications

	Model 102 SB	Model 212 SB	Model 422 SB
<b>Type/Features</b>	Powered subwoofer, sealed enclosure	Powered subwoofer, sealed enclosure	Powered subwoofer, sealed enclosure
<b>Bass Driver</b>	8" long-throw composite cone	10" long-throw composite cone	12" long-throw composite cone
<b>Output Power</b>	100W RMS	125W RMS	225W RMS
<b>Distortion (amplifier)</b>	<0.5%	<0.5%	<0.5%
<b>Frequency Response</b>	34Hz – 250Hz ±3 dB	30Hz – 250Hz ±3 dB	25Hz – 250Hz ±3 dB
<b>Low Level (line)</b>	20kΩ	20kΩ	20kΩ
<b>Peak Output</b>	102dB SPL into 1500 cubic Feet	102dB SPL into 2000 cubic Feet	103dB SPL into 2000 cubic Feet
<b>Dimensions (WxHxD) including side panels</b>	13.2 x 13 x 12.2 in 335 x 330 x 310mm	15.25 x 15 x 16.9 in 388 x 380 x 430mm	17.25 x 17.75 x 16.9in 438 x 450 x 430mm
<b>Weight</b>	31lbs/14.1kg	37.5lbs/17kg	44lbs/20kg
<b>Power Requirements</b>	110-120/220-240V, 50/60Hz, 300W Max	110-120/220-240V, 50/60Hz, 300W Max	110-120/220-240V, 50/60Hz, 500W Max

Specifications are those in effect at the time of printing. Atlantic Technology reserves the right to change specifications or designs at any time without notice. THX is a registered trademark of Lucasfilm Ltd. Dolby Digital, Dolby Stereo, and Dolby Pro Logic are trademarks of Dolby Laboratories Licensing Corporation. DTS is a registered trademark of Digital Theater Systems, Inc.



343 Vanderbilt Avenue Norwood, MA 02062 (781) 762-6300 [www.atlantictechnology.com](http://www.atlantictechnology.com)